

# ELECTRIC HAND HELD NUTRUNNER TOOLS

## X-SW Series

---

*New Series*

Non-reaction Hand held nutrunner tools



## Features

---

- New control method, swing control, reduces reaction force.
- No-load rotation speed is increased by reviewing the mechanical mechanism.
- Lower reaction force and higher speed reduce the load on the operator and improve workability.

**GIKEN**

# Features

- Approximately 83% reduction compared to static tightening
- Approximately 48% reduction compared to conventional blow control

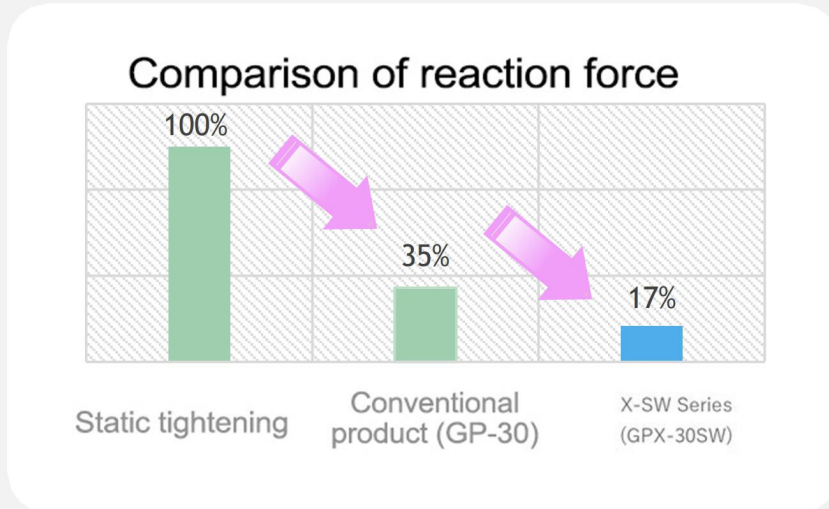

- No-load rotation speed of 4200 rpm by reviewing the mechanical mechanism

# Specifications

model	Applicable Torque (Nm)	Maximum rotation speed (rpm)	controller	cable
GPX-30SW	10~30	4700	GA-T1-N07-MS	GPRK-5M

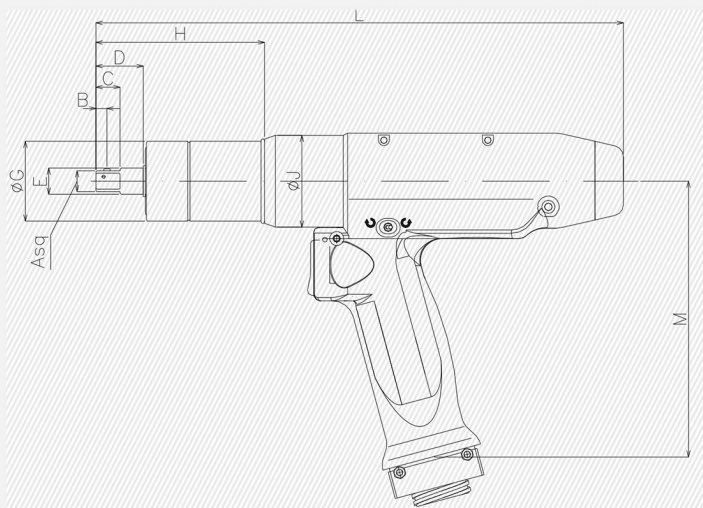

model	Asq	B	C	D	E	φG
GPX-30SW	9.52	5	11	21.5	12	36.5

H	φJ	L	M	Weight (Kg)
113	42	241	127	1.08